



Higher Tier

Volume of cones and pyramids

Instructions

- Use **black** ink or ball-point pen.
- **Fill in the boxes** at the top of this page with your name, centre number and candidate number.
- Answer **all** questions.
- Answer the questions in the spaces provided – *there may be more space than you need.*
- You must **show all your working.**
- Diagrams are **NOT** accurately drawn, unless otherwise indicated.
- If your calculator does not have a π button, take the value of π to be 3.142 unless the question instructs otherwise.

Information

- The marks for **each** question are shown in brackets- *use this as a guide as to how much time to spend on each question.*

Advice

- Read each question carefully before you start to answer it.
 - Keep an eye on the time.
 - Try to answer every question.
 - Check your answers if you have time at the end.
-

1. The diagram shows a cone. The radius is 3 cm and height is 8 cm.

Find the volume of the cone, leaving your answer in terms of π .

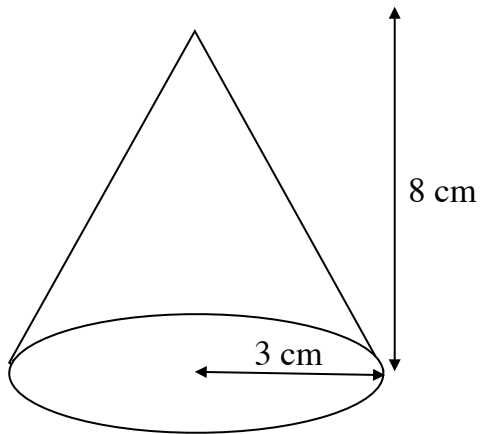

cm^3

.....
(Total for Question 1 is 2 marks)

- 2 A cone has diameter 10 cm and height 12 cm.

Find the volume of the cone.

Give your answer to 3 significant figures.

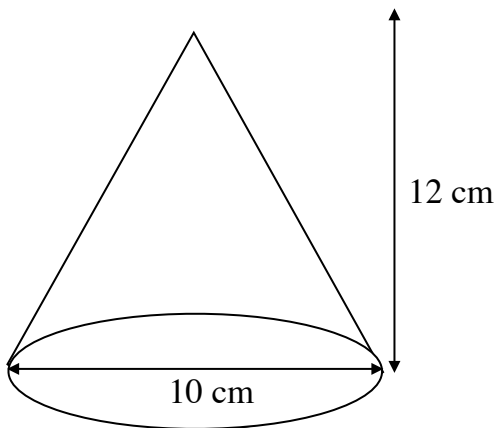

cm^3

.....
(Total for Question 2 is 2 marks)

3. A cone has radius 5 cm and slant height 13 cm.

Find the volume of the cone.

Give your answer to 3 significant figures.

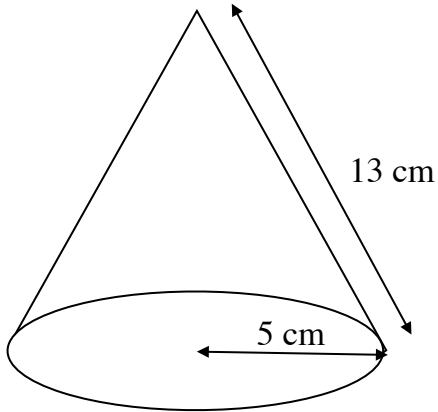

cm^3

.....
(Total for Question 3 is 3 marks)

4. The area of the base of a pyramid is 48 cm^2 .

The vertical height of the pyramid is 10 cm.

Find the volume of the pyramid.

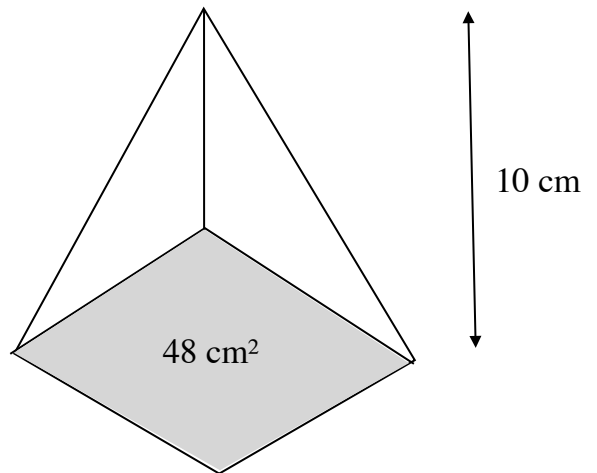

cm^3

.....
(Total for Question 4 is 2 marks)

5. A pyramid has a rectangular base measuring 6 cm by 9 cm.

The vertical height of the pyramid is 11 cm.

Find the volume of the pyramid.

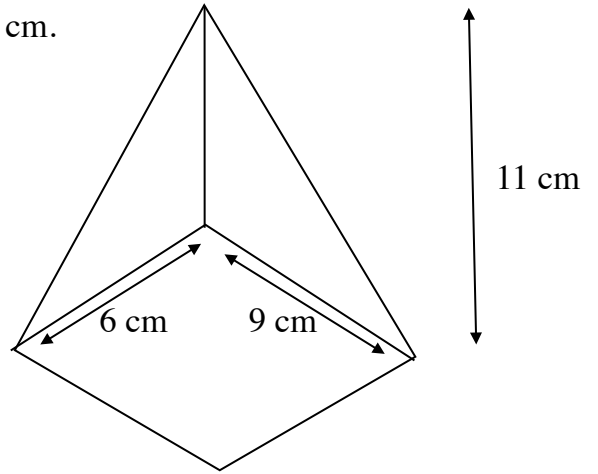

.....
 cm^3

(Total for Question 5 is 2 marks)

6. A square-based pyramid has base side length 8 cm.

The vertical height of the pyramid is 15 cm.

Find the volume of the pyramid.

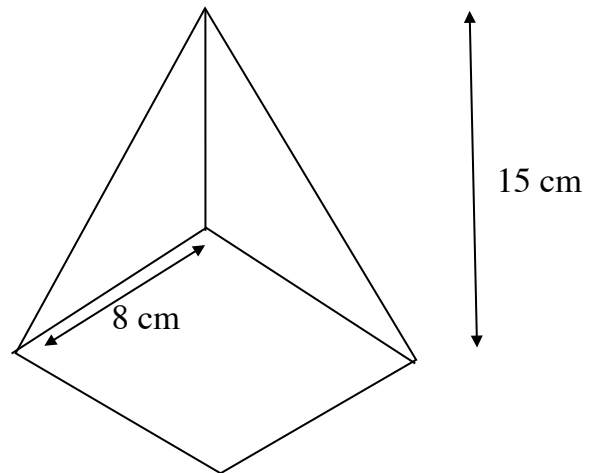

.....
 cm^3

(Total for Question 6 is 2 marks)

7. A pyramid has a triangular base.

The base of the triangle is 10 cm and its perpendicular height is 6 cm.

The vertical height of the pyramid is 14 cm.

Find the volume of the pyramid.

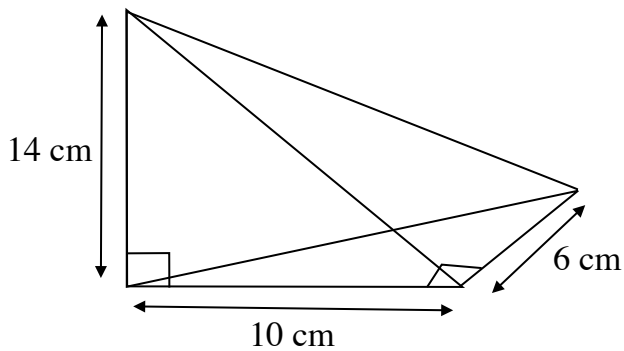

cm^3

.....
(Total for Question 7 is 3 marks)

8. A pyramid has a hexagonal base.

The area of the base is 72 cm^2 .

The vertical height of the pyramid is 13 cm.

Find the volume of the pyramid.

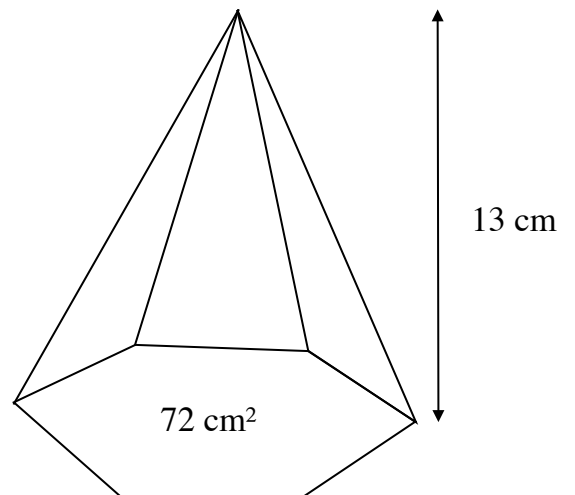

cm^3

.....
(Total for Question 8 is 2 marks)

9. The volume of a cone is $200\pi \text{ cm}^3$.

The radius of the cone is 5 cm.

Find the height of the cone.

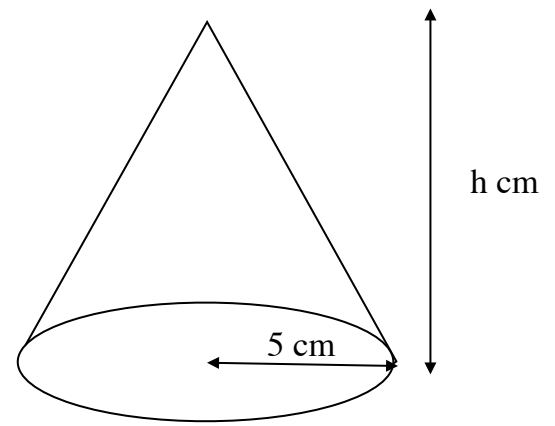

cm

.....
(Total for Question 9 is 3 marks)

10. The volume of a cone is $150\pi \text{ cm}^3$.

The height of the cone is 8 cm.

Find the radius of the cone.

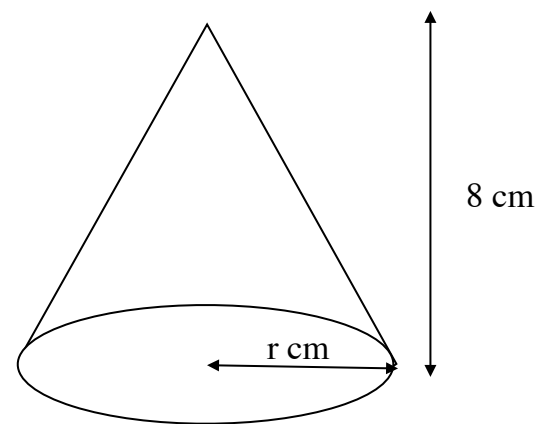

cm

.....
(Total for Question 10 is 3 marks)

11. A pyramid has a square base with side length 6 cm.

The volume of the pyramid is 144 cm^3 .

Find the vertical height of the pyramid.

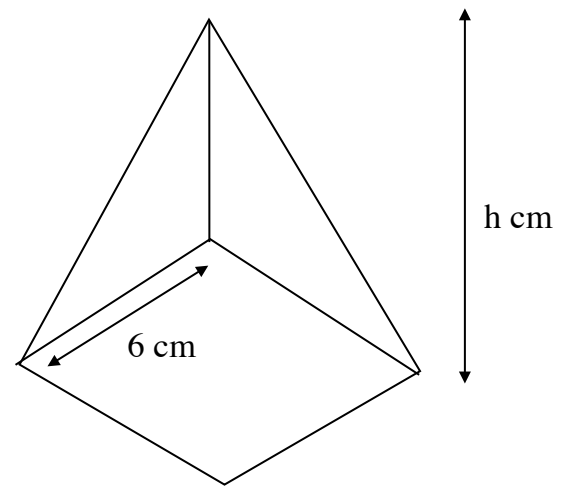

cm^3

.....
(Total for Question 11 is 3 marks)

12. A cone has a volume of $384\pi \text{ cm}^3$.

The slant height of the cone is 10 cm.

Find the radius of the cone.

Give your answer to 3 significant figures.

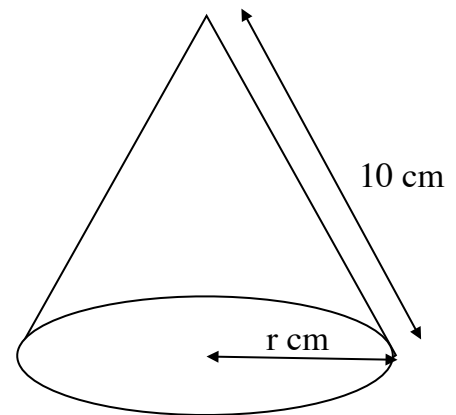

cm

.....
(Total for Question 12 is 4 marks)

13. A solid is made from a cuboid and a square-based pyramid on top.

The cuboid has dimensions 8 cm by 6 cm by 10 cm.

The pyramid has a vertical height of 7 cm.

Find the total volume of the solid.

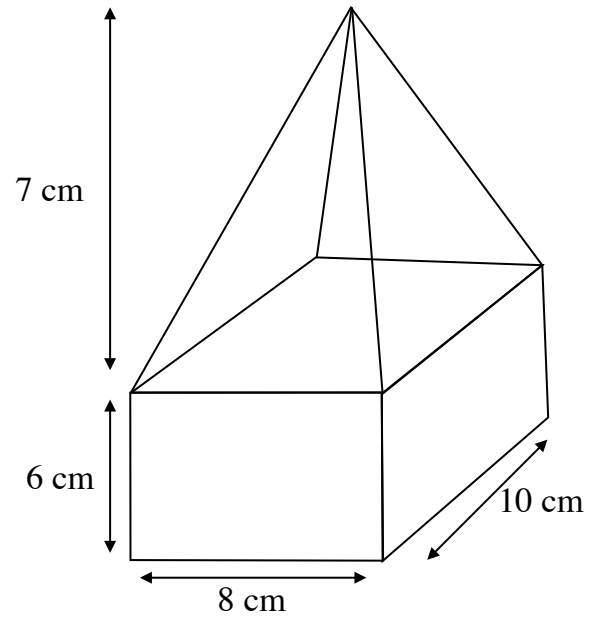

cm^3

.....
(Total for Question 13 is 4 marks)

14. A solid is made from a cylinder and a cone on top.

The cylinder has radius 4 cm and height 12 cm.

The cone has radius 4 cm and vertical height 9 cm.

Find the total volume of the solid.

Give your answer in terms of π .

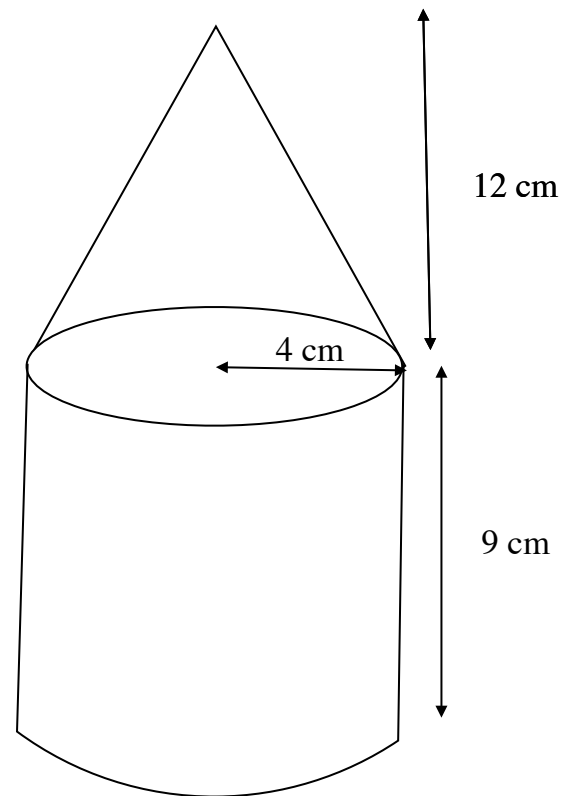

cm^3

.....
(Total for Question 14 is 4 marks)

15. A cone and a cylinder both have radius 3 cm.

The height of the cone is 12 cm.

The height of the cylinder is h cm.

The volume of the cone is four times the volume of the cylinder.

Find the value of h .

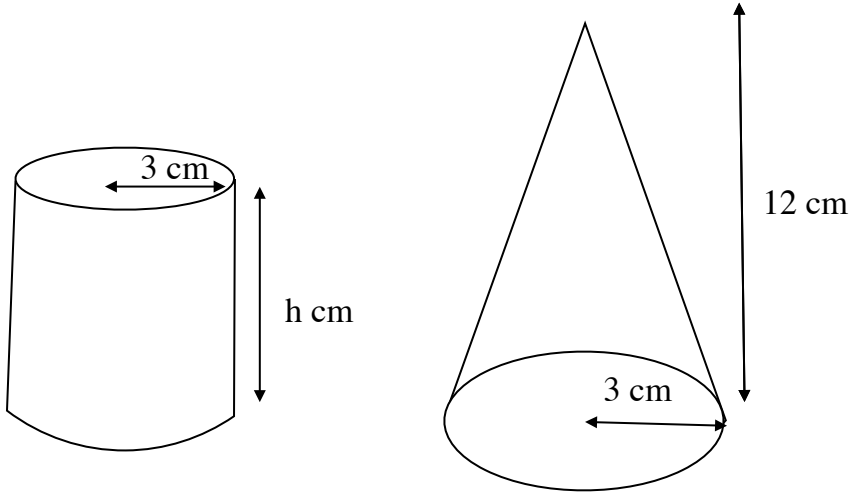

cm

.....
(Total for Question 15 is 4 marks)

16. A solid metal cone has radius 3 cm and height 8 cm.

The density of the metal is 7.5 g/cm^3 .

Find the mass of the cone.

Give your answer to 3 significant figures.

.....
g

(Total for Question 16 is 4 marks)

17. A pyramid has a square base of side length 6 cm and a vertical height of 10 cm.

The density of the material is 2.4 g/cm^3 .

Find the mass of the pyramid.

Give your answer to 3 significant figures.

g

.....
(Total for Question 17 is 3 marks)
