



JP Maths

Revision



Attempt the paper
before watching the
solutions!

[https://www.youtube.com/
@JPMathsRevision](https://www.youtube.com/@JPMathsRevision)



FOUNDATION / HIGHER TIER

Exact Trig Values



INSTRUCTIONS

- Use **black ink** or ball-point pen.
- **Fill in the boxes** at the top of this page with your name, centre number and candidate number.
- Answer **all** questions.
- Answer the questions in the spaces provided – *there may be more space than you need.*
- You must **show all your working.**
- Diagrams are **NOT** accurately drawn, unless otherwise indicated.
- If your calculator does not have a π button, take the value of π to be 3.142 unless the question instructs otherwise.



INFORMATION

- The marks for **each** question are shown in brackets– *use this as a guide as to how much time to spend on each question.*



ADVICE

- Read each question carefully before you start to answer it.
- Keep an eye on the time.
- Try to answer every question.
- Check your answers if you have time at the end.



You've got this!

1. Complete the following table:

x°	0	30	45	60	90
$\sin(x^\circ)$					
$\cos(x^\circ)$					
$\tan(x^\circ)$					

(Total for Question 1 is 4 marks)

2. Write down the value of $\sin(30^\circ)$

.....
(Total for Question 2 is 1 mark)

3. Write down the value of $\cos(60^\circ)$

.....
(Total for Question 3 is 1 mark)

4. Write down the value of $\tan(45^\circ)$

.....
(Total for Question 4 is 1 mark)

Non-Calculator

5. Write down the value of $\sin(45^\circ)$

.....
(Total for Question 5 is 1 mark)

6. Write down the value of $\cos(30^\circ)$

.....
(Total for Question 6 is 1 mark)

7. Write down the value of $\tan(60^\circ)$

.....
(Total for Question 7 is 1 mark)

8. Write down the value of $\sin(60^\circ)$

.....
(Total for Question 8 is 1 mark)

9. Write down the value of $\cos(45^\circ)$

.....
(Total for Question 9 is 1 mark)

10. Work out the value of x .

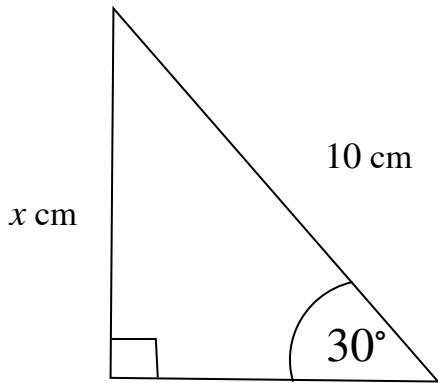

cm

.....
(Total for Question 10 is 2 marks)

11. Work out the value of x .

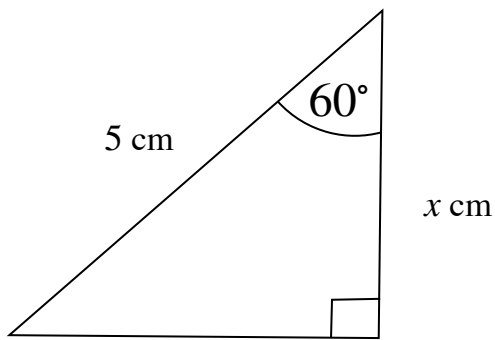

cm

.....
(Total for Question 11 is 2 marks)

12. Work out the value of x .

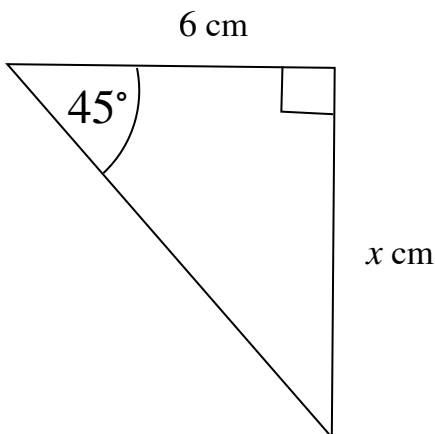

cm

.....
(Total for Question 12 is 2 marks)

13. Work out the size of the angle marked x° .

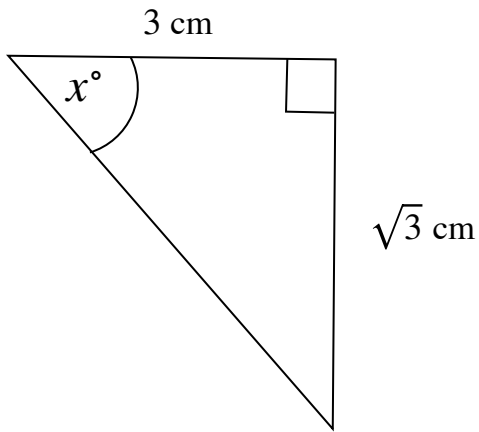

.....
(Total for Question 13 is 2 marks)

14. Work out the size of the angle marked x° .

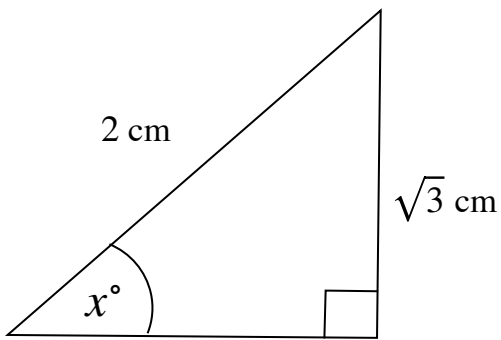

.....
(Total for Question 14 is 2 marks)

15. Work out the size of the angle marked x° .

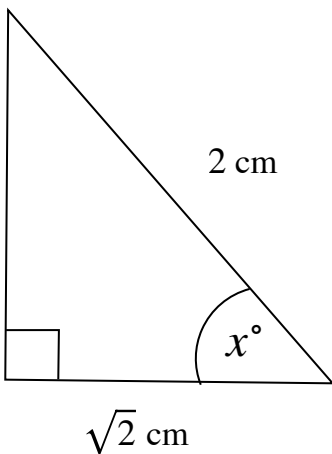

.....
(Total for Question 15 is 2 marks)
